

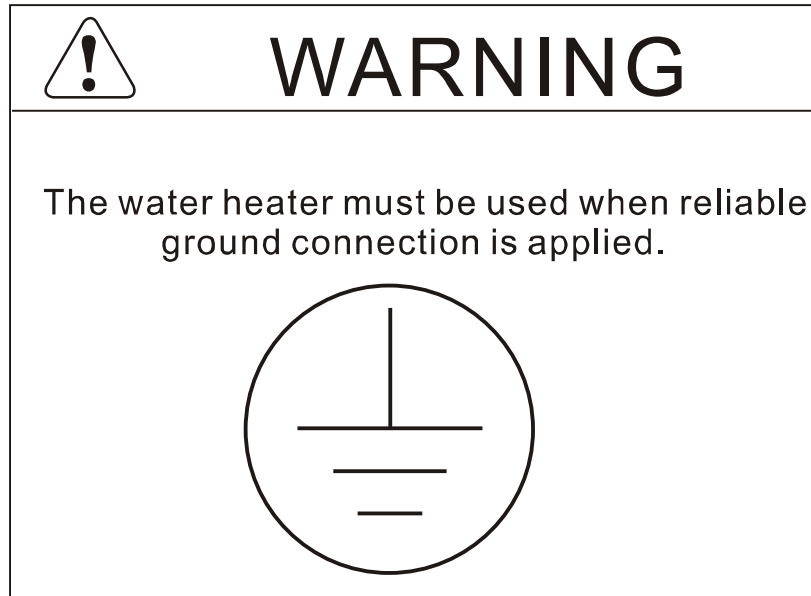

Air source heat pump water heater

Operation & Installation Manual



The manual provides many important security tips for you to use the air source water heater. Please read the manual carefully before use the unit.

All safety tips is together with safety warnings. The followings are the meanings of each warning:

 **ATTENTION** There will be potential danger for you or others.

 **WARNING** Wrong operations may lead to the life risks or serious injuries.

 **DANGER** Wrong operations will lead to the life risks or serious injuries.

Content

1. Preface	1
2. Safety Attention	2
3. Specification	4
1) Appearance	4
2) Features	4
3) Working Principle	5
4) Dimension	6
5) Performance Parameters	7
4. Performance Characteristics	8
5. Installation	9
1) Installation Sketch Map	9
2) Choose the Suitable Unit	11
3) Storage and Transportation	11
4) Open-package Inspection	11
5) Installation Position	12
6) Hydraulic Connection	13
7) Electrical Connection	14
8) Trial Operation	14
6. Usage	15
6.1) The function diagram of the wire controller	15
6.2) The usage of the wire Controller	17
7. Maintenance and repair	27
7.1) Maintenance	27
7.2) The normal failure and solution	27
8. Appendix	28
8.1) PCB Controller	28
9. Caution & Warning	29

1. Preface

Dear customer:

Thank you so much for choosing our products!

Our water heater has features of excellent quality and good performance. Please read this manual carefully and strictly follow its operation to install, run and maintain the unit. Any problems you meet during using the water heater, please contact us refer to the phone number or the address on guarantee card, we will serve for you without hesitation.

Our manual is accordance with the unit for the first publication. We reserve rights to change specification and design of units which will lead to manual content different from our unit. please understand.



Warm Tips!



Our heat pump water heater can provide with sanitary hot water, and there is some advice for you to save power consumption when you are using our heat pump water heater. we suggest that the target temperature should be 48°C (in summer and autumn) or 55°C (in spring and winter).

2. Safty Attention

Safty Attention:

To prevent users' personal property damage and operate the unit in the correct and safety way, please carefully read the main contents in the manual. Based on completely understanding the following contents (the signs and diagrams) then read the body text, comply with the following notice.





Marking	The significance of the marking
 Warning	The false operation may result in casualties.
 Attention	The false operation may result in terrible injuries or property damage.

Icon	The significance of the icon
	It means forbidding, the detail content are within the icon or expressed by graph or words closed to the icon.
	It means Enforcement. The detail content are within the icon or expressed by graph or words closed to the icon.
	It means attention including warning. The detail content are within the icon or expressed by graph or words closed to the icon.



1. The damage means noneed of in hospital, long-term treatment, make a general reference to injure, burn and electric shock.
2. Material damage means property and material loss.











Warning

Installation Warning	 Professional installer is required	The heat pump must be installed by qualified personnel to avoid improper installation which can lead to water leakage, electric shock or fire.
	 Earth wire is required	Please make sure that the unit and power connection have good earthing, otherwise may cause electric shock.
	 Concentration limits	When installing the unit in a small room, please take measures to prevent the asphyxia caused by the leakage of refrigerant.
Operation Warning	 DO NOT	Under no circumstances should you put your fingers or tools in to air-ducts of the unit.
	 Shut off the power	When there is something wrong or strange smell, the power supply should be shut off to stop the unit. Continuing to run may cause electrical short of fire.

2. Safety Attentions

Installation Attentions	 Confirm the installation location	It could not be installed near the flammable gas which may cause leakage. Once the flammable gas is leaking around the unit, it may cause fire.
	 Confirm the fixed measure	Confirm the foundation is solid.

Dislocation and Repair	 Entrust	When the unit needs to be removed or re-installed, please engage a qualified person to carry out the work. Improper installation will lead to water leakage, electric shock, injury or fire.
	 Prohibit	The user must not repair the unit, otherwise the warranty will be invalidated.
	 Entrust	When the unit needs to be repaired, please entrust a qualified person of the dealer to do it. Improper movement or repair of the unit will lead to water leakage, electrical shock, injury or fire.

Operation Attention	 Warning	This equipment is applied to professional and experienced operators to use, kids and unhealthy persons be cautious on this. Please read the manual carefully before operating.
	 Check the installation site	If the unit is not to be used for any long period and the ambient temperature is below 0 degree, please drain the water in the tank to prevent freezing and consequent damage.
	 Shut off the power	When being cleaned, shut off the power to the unit, otherwise injury could occur.
	 Prohibit	Please use a suitable fuse, otherwise it may cause failure and fire.
	 Prohibit	Do not spray flammable towards or around the unit, otherwise it could cause a fire.

3. Specification

1. Appearance

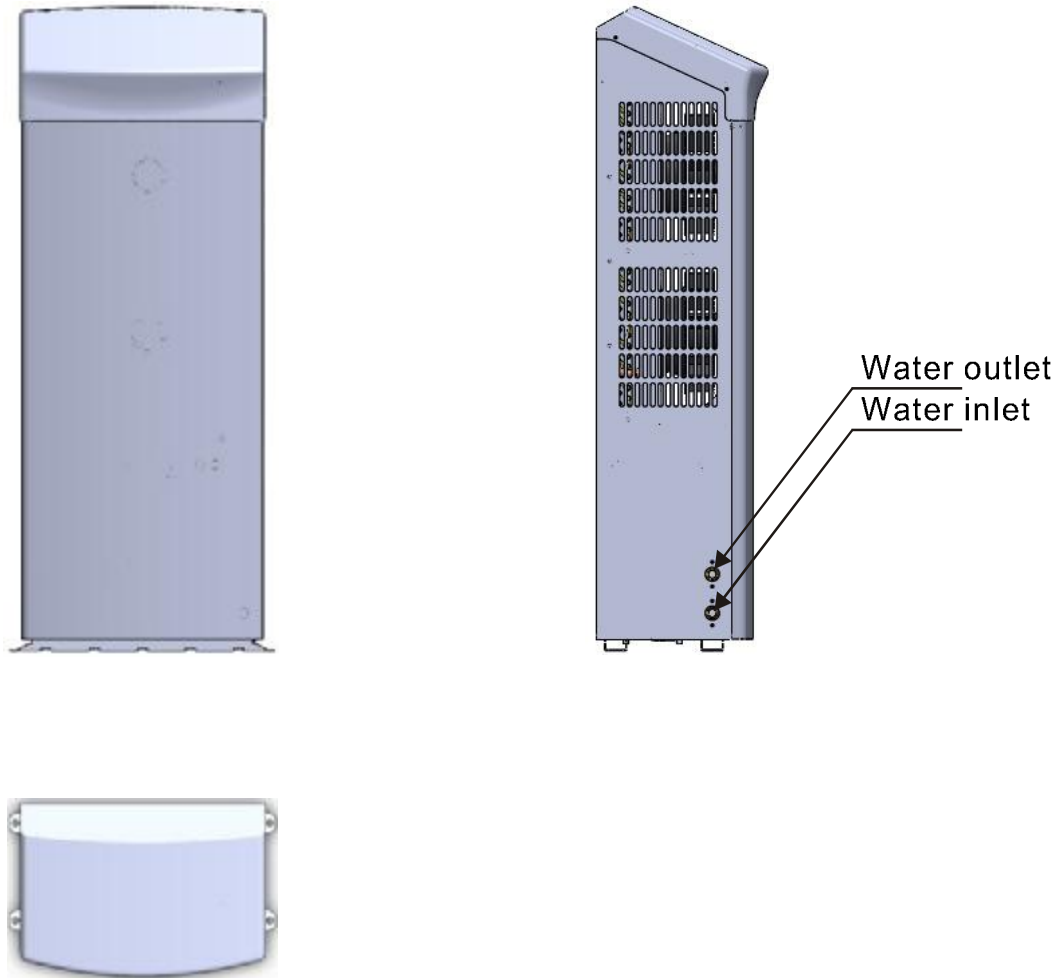

2. Features

- **Monolithic Structure**
Easy installation, less floor space occupation, more sanitary hot water
- **Better Safety Performance**
It is more safety than electric/gas water heater, without worrying about electricity/gas leakage.
- **Energy-saving and Eco-friendly**
The power consumption of heat pump water heater is only one quarter of that of the electric water heater, and our unit has no pollution to the environment.
- **Much more sanitary hot water**
Our unit can provide much sanitary hot water whenever you want, and keep the water temperature constant. What is more, the family can use hot water from different pipe outlet at the same time. It is especially suitable for villas or houses with bathtub.

3. Specification

3. Working Principle

System diagram:

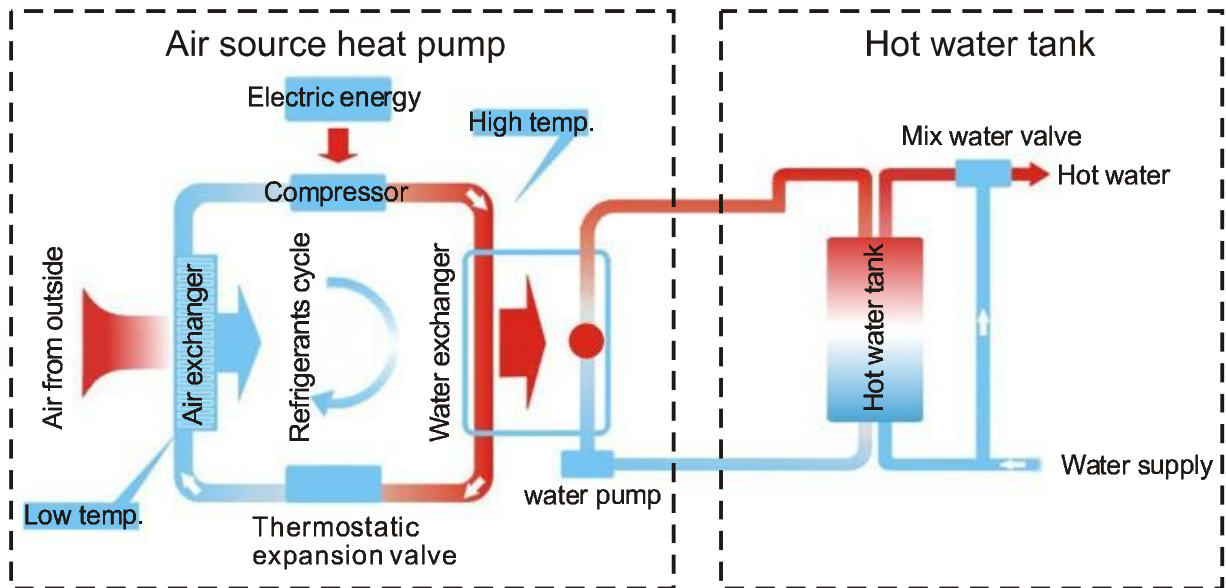

System Principle:

- ① Refrigerant is compressed into vapor with high temperature and high pressure when it goes through the compressor;
- ② The high temperature and high pressure vapor (the non-fluorine refrigerant) transfer its heat to water when it goes through heat exchanger, then the heated water will be pumped into storage tank, and the non-fluorine refrigerant turns into liquid status.
- ③ The liquid refrigerant drops to low temperature and low pressure liquid when it passes by throttling device. When it goes through heat exchanger, the liquid refrigerant absorbs much heat from the environment and turns into gas status by the function of fan motor. So the air temperature around the heat exchanger will drop down rapidly. Then the heated refrigerant in the gas status flows into compressor again.
- ④ The above procedure will start once again. So with the help of refrigerant, the system transfers the heat from the surrounding air into water, then the water can be heated.

3. Specification

4. Dimensions

Model: PASHW020

Unit: mm

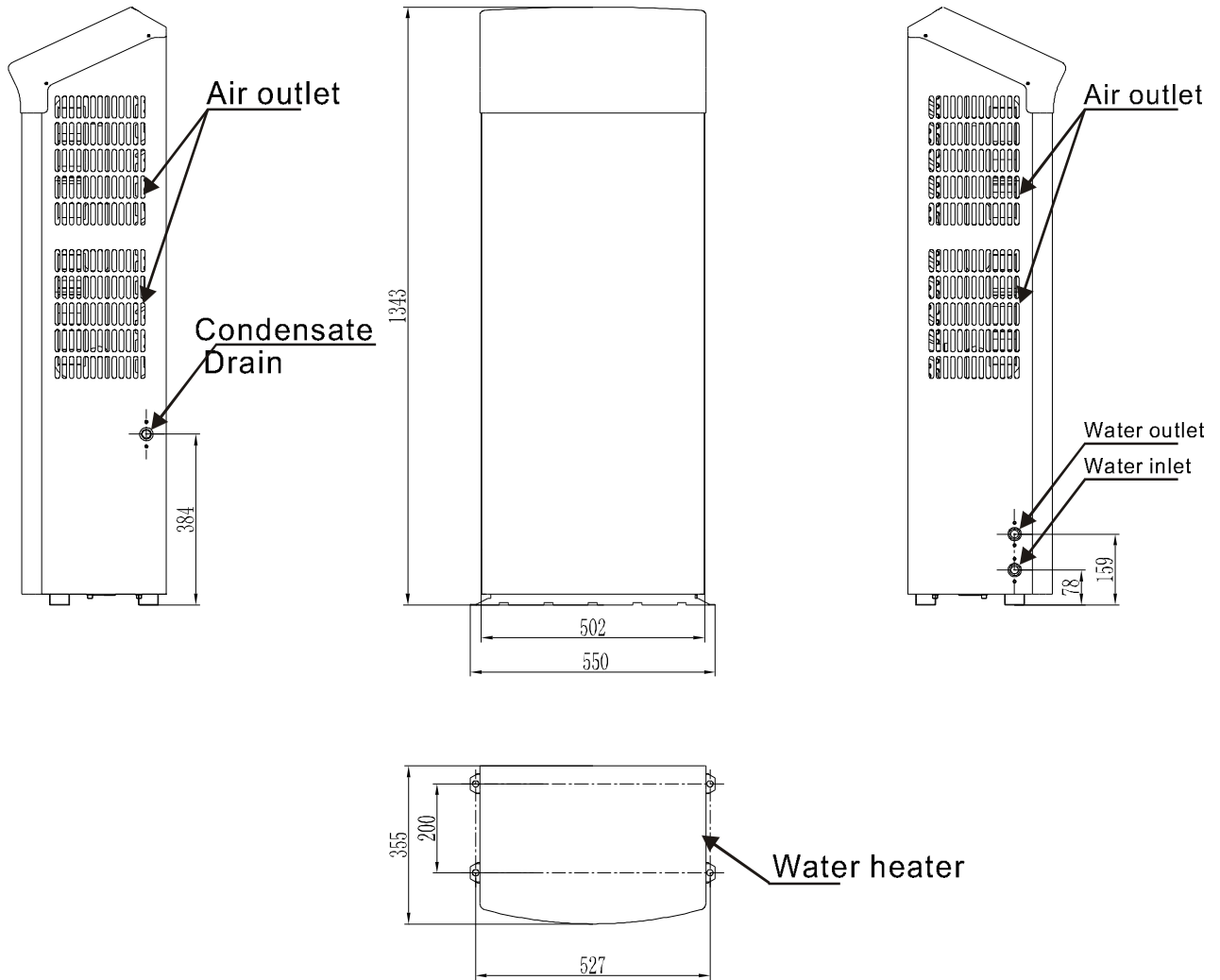

4. Specification

5. Performance Parameters

Model		PASHW020
Heating capacity	kW	4.85
Rated power input	kW	1.25
Rated current input	A	5.43
Max. Power input	kW	1.50
Max. Current input	A	6.52
Power supply	V/Ph/Hz	230V~/50Hz
Compressor quantity		1
Compressor		Rotary
Fan motor speed	RPM	1580
Fan motor quantity		2
Water pump power	W	/
Noise	dB(A)	52
Water inlet	DN	20
Water outlet	DN	20
Condensate drain outlet	DN	20
Range of ambient temp.	°C	-7~43
Rated water flow	m ³ /h	≥ 1.0
Target Water temp. Set	°C	55
Net dimensions	mm	See the drawing of the unit
Shipping dimensions (L/W/H)	mm	See the package label
Net weight	kg	See the nameplate
Package weight	kg	See the package label

*Testing conditions:

Ambient temp.(DB/WB): 15°C/13°C, Water inlet: 15°C, Water outlet: 45°C.

Operation range:

The range of the operating ambient temperature: -7~43°C

The range of the operating water temperature: 9~55°C

4. Performance Characteristics

Performance Characteristics

Heating Capacity

- Because the supplied hot water absorbs heat from the surrounding air and releases the heat at the heat exchanger side. Once the ambient temperature goes down, the heating capacity may decrease accordingly.

3 Minutes Protection

- When the unit is turned off after running and the user immediately starts the unit or turns on the manual switch, the unit will not run within 3 minutes. This is one of the main controller functions to protect the compressor.

Defrosting Function in Heating Mode

- When there is frost on some part of the unit in heating mode, the machine will automatically defrost to promote heating capacity (2 to 10 minutes). Under the defrosting process, the fan motor of the unit will stop running and the compressor will continue running.

Water Source

- The unit can only use tap water. Please do not use the water from a lake, river or underground which is not treated.

Power Supply Disconnection

- If power is cut when the machine is running, the unit will stop immediately. If the unit is mis-working because of thunder, radio wave, power net fluctuation, please turn off the power switch by hand. After the unit power supply is available, the user can then press the ON/OFF key on the controller.

Current Leakage Protector

- The unit must be connected with power net through a current leakage protector.

Water Pressure Protection

- In the water system will be installed with the P&T valve. When the pressure/temperature of the water tank is higher than the target set point of the P&T valve, the P&T valve will open and release automatically. During this process, there will be some water flow out, please do not block up this port.

5. Installation

1. Installation Sketch Map

1.1 Water system installation sketch map

Unit: mm

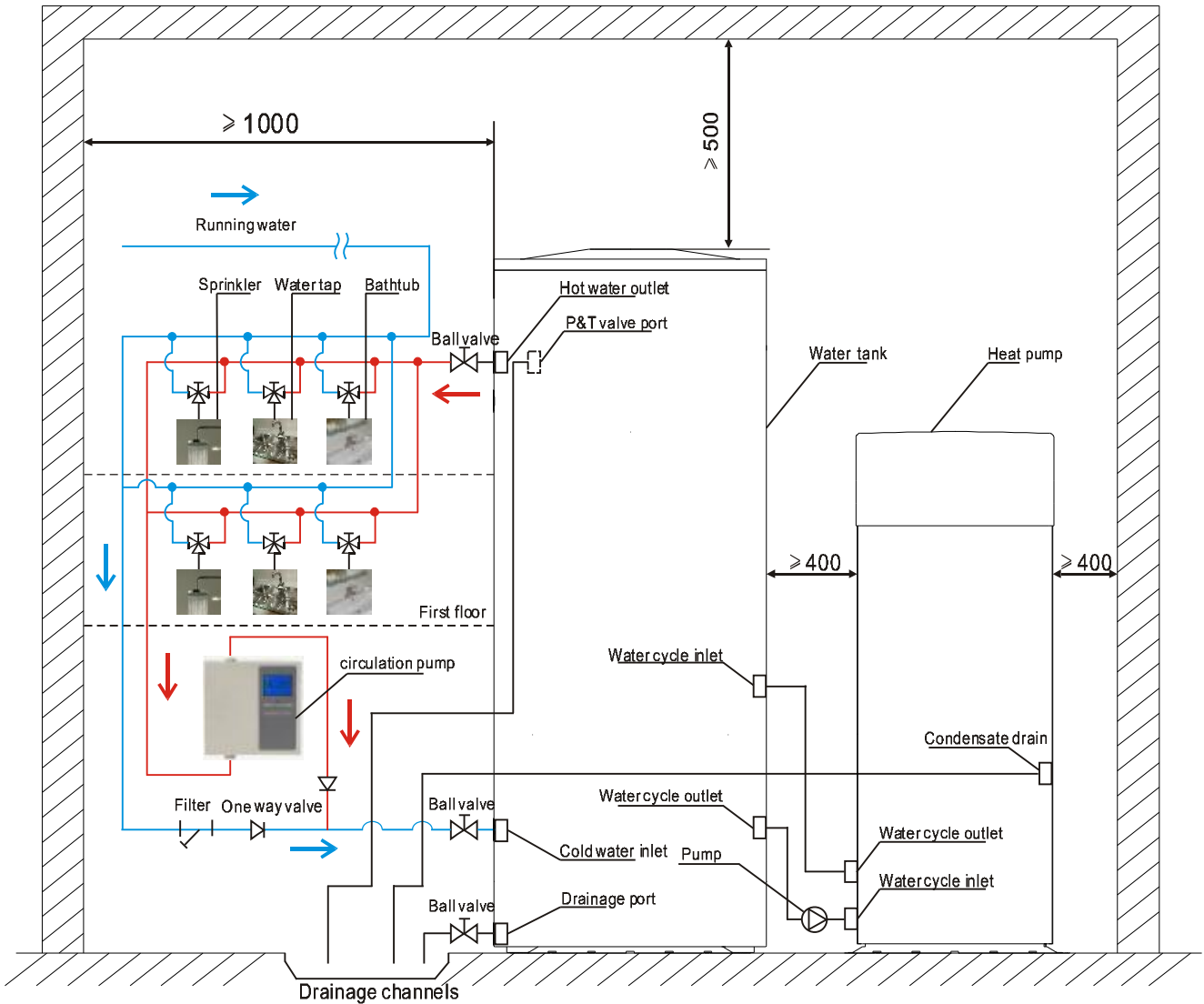

ATTENTION

P&T valve is a necessary component of the tank.
Do not block the drain outlet.
Lead the drain pipe to an open drain channel.
Please obey the above instructions to avoid any possible injuries or unexpected accidents

5. Installation

1.2 Installation sketch map of water heater and storage tank

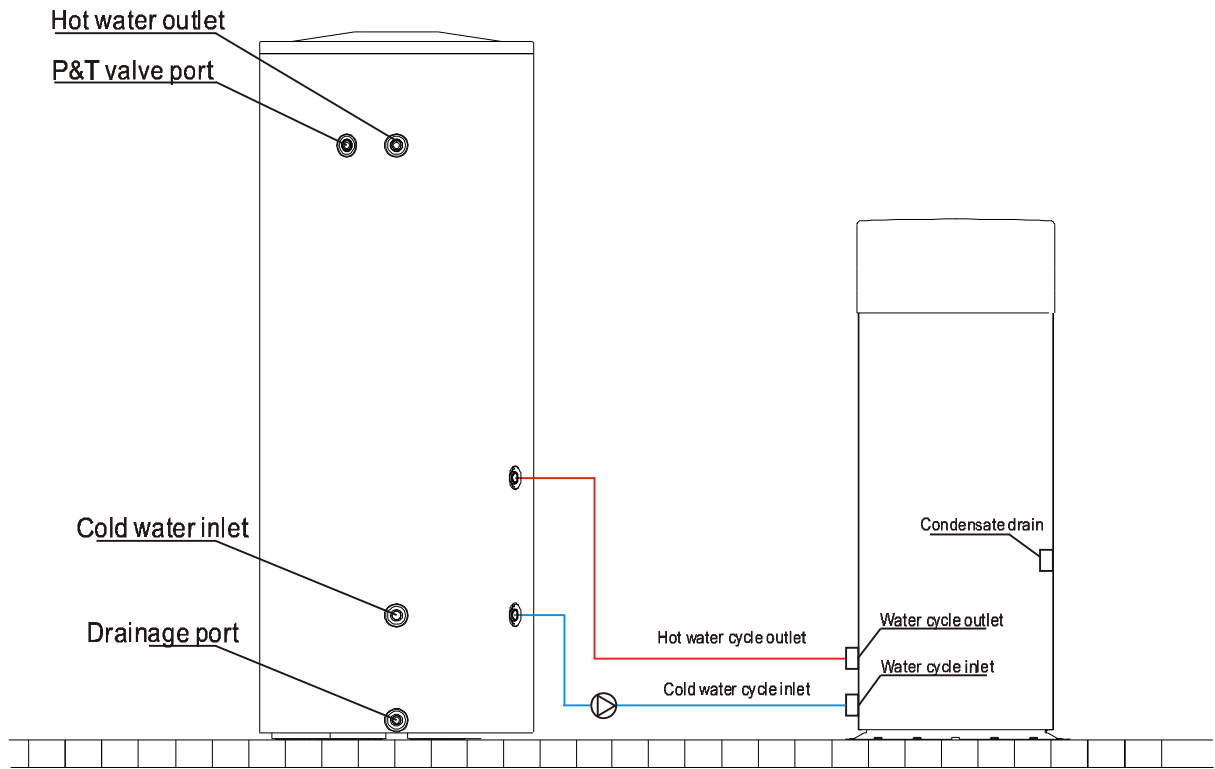

1.3 Installation working sketch of water heater and storage tank

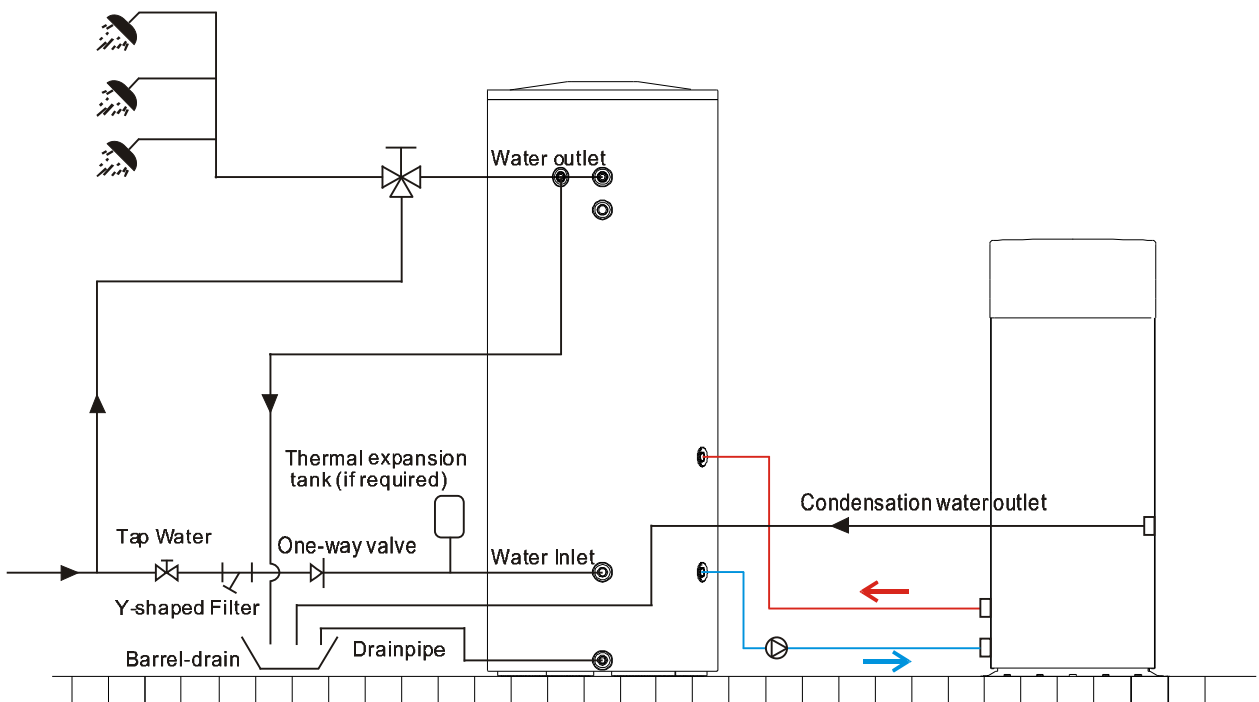

5. Installation

2. Choose the suitable unit

This water heater is specially suitable for large houses or villas, and the public place where need much hot water. Please confirm whether your practical situation is fit for the below table.

People	Model
<10	PASHW020

Attention: The above is just for reference, the data is according to the data of 50L/person each day. please choose the unit according to local ambient temperature and actual usage habits.

3. Storage and Transportation

- Generally, it's better to use a container to transport the water heaters and store them in a suitable and dry place. For short distance carrying, please be careful and ensure the maximum inclination is no more than 60. During transportation and storage, the ambient temp is better from -10°C — +43°C.
- There should be some protection against shock during transportation, so that can prevent the unit from shaking.
- During transportation and lifting, please take some protection for the unit to prevent it from inclining and turnover, do not damage the cabinet.

4. Open-package Inspection

- Please check whether the unit package is in good condition or not. After opening the package material,
- please check if there is some damage on the cabinet or something wrong to the unit.
- Please check the accessories to confirm whether it is the same with packing list.
- If there are some damage or lack of parts, please connect to the factory or the transport department
- If there are some other problem beyond cabinet damage, please inform our company at once.

5. Installation

5. Installation Position

5.1 When you select the position to install the unit, please consider the following points:

- Enough space for installation and maintenance should be preserved.
- Place the unit away from the living area to decrease the vibration and the noise, like: on the balcony, flat roof or other flat places.
- When the unit needs to be installed on the flat roof or other place, do not choose the site which is with heavy wind, heat vapor, flammable gases or near the exhaust outlet of some devices.
- In the multi-story building, heat pump water heater and other household equipment should be centralized installed, which not only can save much wire, installation fee, but also is convenient for inspection and management.
- When there are many units need to be installed, the distance between the units should $>2.5\text{m}$ to avoid noise and sympathetic vibration.

5.2 Installation Space

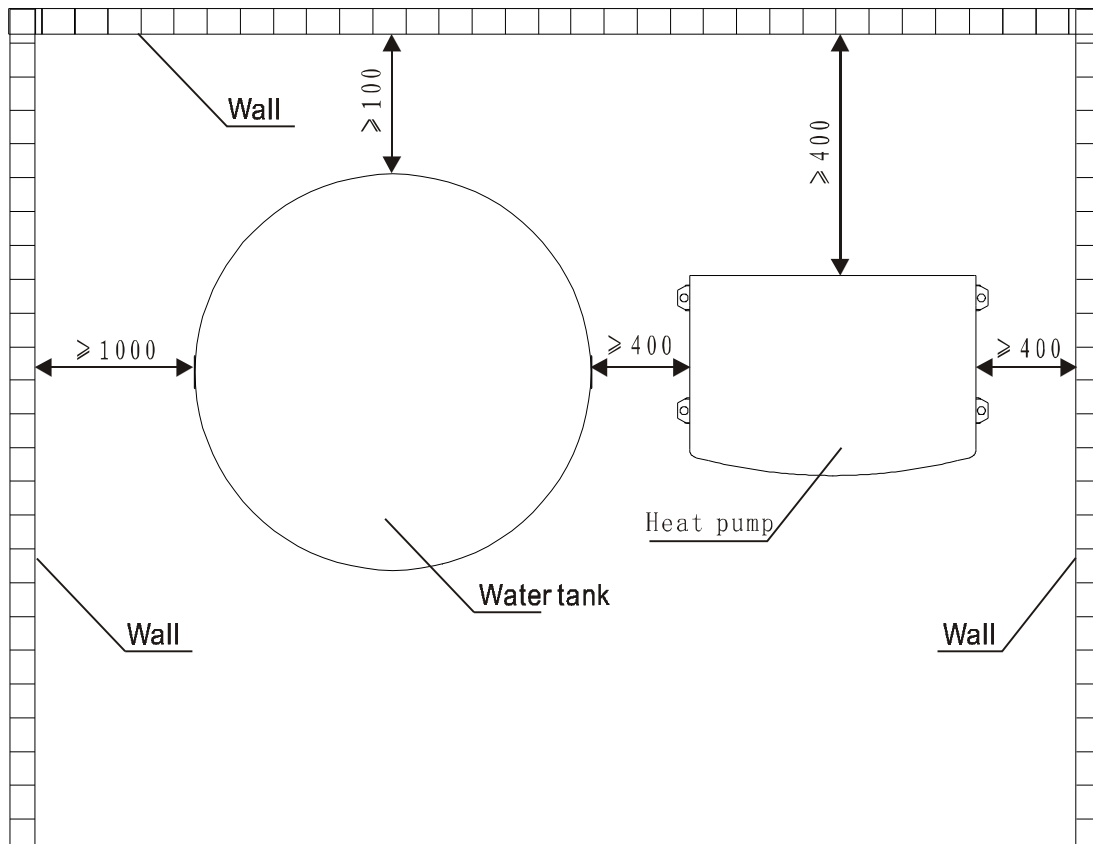

5. Installation

6. Hydraulic Connection

Please pay attention to the points below when connecting the water pipes:

- Try best to decrease the resistance in water pipes.
- Inner surface of whole pipe system should be clean, no rusty spots and dirt to avoid any pipe blocks.
- There should be no leakage in the water circuit system, or the unit performance will be affected, or your living and working environment be disrupted.
- Add one-way valve and safety valve in water way.
- When connect the water heater to the water tank, please use flexible pipe to prevent vibration transmitting.
- Hydraulic system pipes should be kept warm by high quality insulation material, to decrease heat exchange between water system and the environment.
- Please install auto. exhaust valve at the highest point of the water system.
- Please install drainage valve at the lowest point of the water system.
- Do not use ground water, river water, lake water which has not been processed.
- The installation of water pipes have to be accordance with DIN1988 standard (to avoid higher water pressure, please install a discharge valve).
- Please set a filter in front of the cold water inlet to avoid the dirt going into the water pipe.
- When connecting the water pipes, please prevent any pollution going into pipes.
- The male specification of P&T valve is G3/4". After installation, please assure that the drainage pipe is open to the atmosphere.
- If there is a drainage hose pipe connecting the discharge outlet of P&T valve, please assure its direction is down and its outlet is open to the air.



Attention

At least pull once half a year the handle of one way valve in order to remove the sediment of Calcium Carbonate. Please confirm the device is with no jam. The temperature of the water from the outlet of the valve may be higher than expected and please take care to avoid burns.

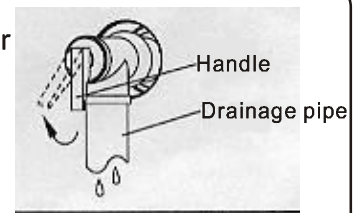

5. Installation

7. Electrical Wiring

- Instruments should be installed in accordance with national wire installation rules.
- Wire connection must be made by qualified electrician.
- Power off the unit before you inspect the electrical wiring connection.
- Before wiring, confirm the rated voltage of the unit as shown on its nameplate, then carry out the wiring strictly following the wiring diagram.
- Check whether the power supply to the unit is in accordance with the unit capacity or not, if not, please change the power supply. Do not start up the unit with wrong power supply.
- There should be an electric circuit protector between the unit and the power supply. Please select the protector specification according to the relevant electric standard and product technical explanation.
- If the power cable is damaged, you must purchase a new one from the factory or a qualified agent, or other products with the same certificates.
- Make sure the earthing is in good condition, and there should be no virtual earthing connection which will cause injuries to people.



Attention

Power cable shall be arranged in neat and reasonable way and in accordance with national routing rules for installation.

8. Trial Operation

8.1 The examine before trial operation

- Make sure the water tank is full of water and the water pipes are installed well.
- Check the power supply distribution system and ensure the voltage is in normal condition and the earth wires and wiring connections are in good condition.
- Check the unit status: When the unit is powered on, observe whether the indicator light and the temperature of the controller are working normally.

8.2 Test running

- Starting the unit by the wire controller.
- First, start up water pump (ensure water can be pumped), after 1 min, start up fan motor.
- When the unit is operating, check the unit whether it is with abnormal sounds, if so, the unit should be stopped and examined at once.
- Check the water temperature in the water tank to see whether it is normal.
- It may need 4 ~ 8 hours for the unit to achieve the target temperature for the first time depends on the water and ambient temperature.





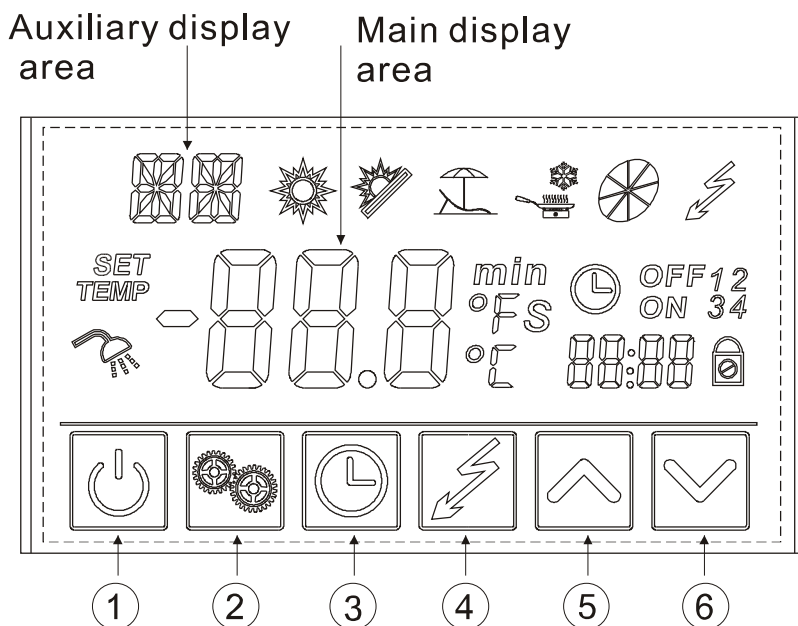

6. Usage

6.1 The function diagram of the wire controller

1. Function of wire controller













1) Function of key

NO.	Button	Name	Function
①		ON/OFF	Turn on/off the unit.
②		Mode	Switch unit running modes or save setting parameters.
③		Clock	Set the clock or the timer.
④		Electric Heater	Turn on/off the electric heater or switch fan modes.
⑤		Up	Move up or increase parameter values.
⑥		Down	Move down or decrease parameter values.

6. Usage

2) Function of icons

Status icon	Name	What it means
	Heating	Shows that the unit is in heating mode.
	Eco.heating	Shows that the unit is in eco.heating mode.
	Vacation	Shows that the unit is in vacation mode.
	Cooling	Shows that the unit is in cooling mode.
	Fan	Shows that the fan is on and the speed of the fan.
	Electric heater	Shows that the electric heater is on.
	Set temperature achieved	Shows that the water temperature has reached the target point and the unit shut off automatically.
SET	Parameter setting	Shows that the parameter is adjustable.
TEMP	Temperature	Shows that the temperature is non-adjustable (measured value).
	Timer & ON	Shows that the unit will be turned on by the timer automatically.
	Timer & OFF	Shows that the unit will be turned off by the timer automatically.
min	Minute	Shows that the main display area displays the minute.
S	Second	Shows that the main display area displays the second.
°C	Centigrade	Shows that the temperature in Main display area or Auxiliary display area is in °C.
°F	Fahrenheit	Shows that the temperature in Main display area or Auxiliary display area is in °F.
	Lock	Shows that the keyboard is locked.

6. Usage

2. Usage of wire controller

2.1 Turn ON/OFF the unit

Press "⏻" and hold for 0.5s in the standby interface of the wire controller to turn on the unit and at this time the main display area shows the water outlet temperature.

Press "⏻" and hold for 0.5s in the running interface of the wire controller to turn off the unit and at this time the main display area shows OFF.

Note: The ON/OFF button can only be used to turn on/off the unit in standby or running interface of the wire controller.

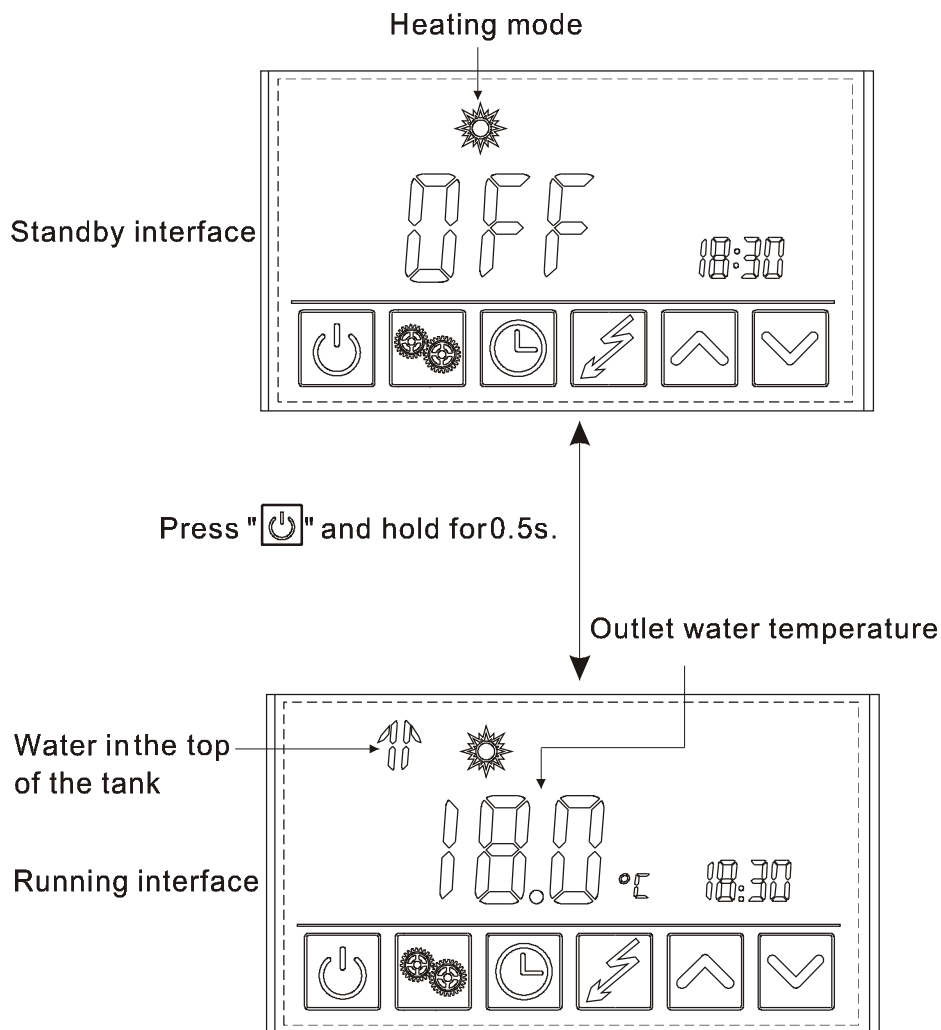

2.2 Mode selection





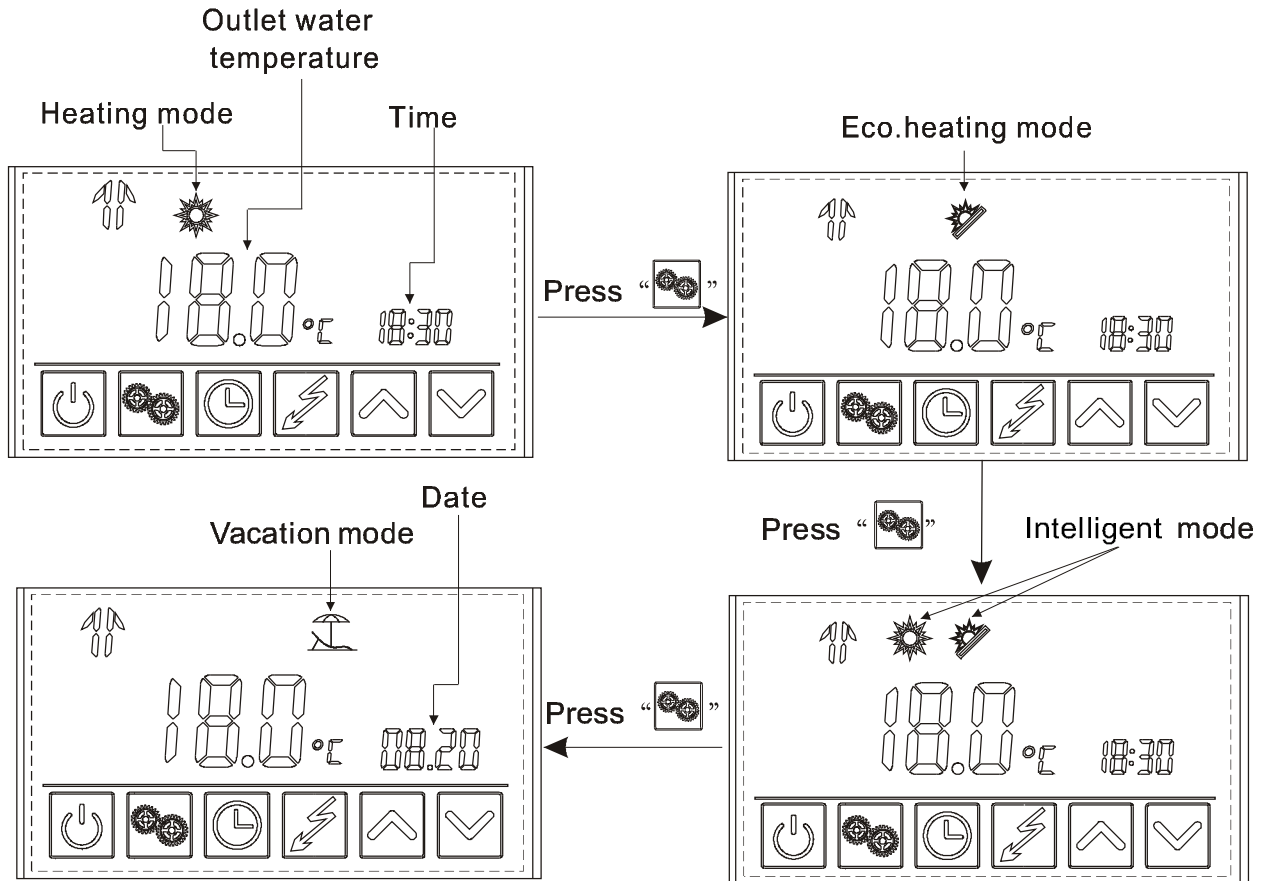

Press "⚙️" to select the mode from Heating, eEco.heating, Intelligent, Vacation in the standby or running interface.

For example:

6. Usage



2.3 Target temperature checking and setting

In the standby or running interface, press " " or " " once to check the target temperature of the outlet water. Press " " or " " again to change the target temperature. After making the changes to the parameter, press " " to confirm or " " to cancel the changes, then return to the previous interface. If no operations are performed on the keypad for 5s, the controller exits the parameter modification menu by timeout and the changes are confirmed. Example: Change the target temperature from 50°C to 55.5°C when the actual outlet water temperature is 18°C.

6. Usage

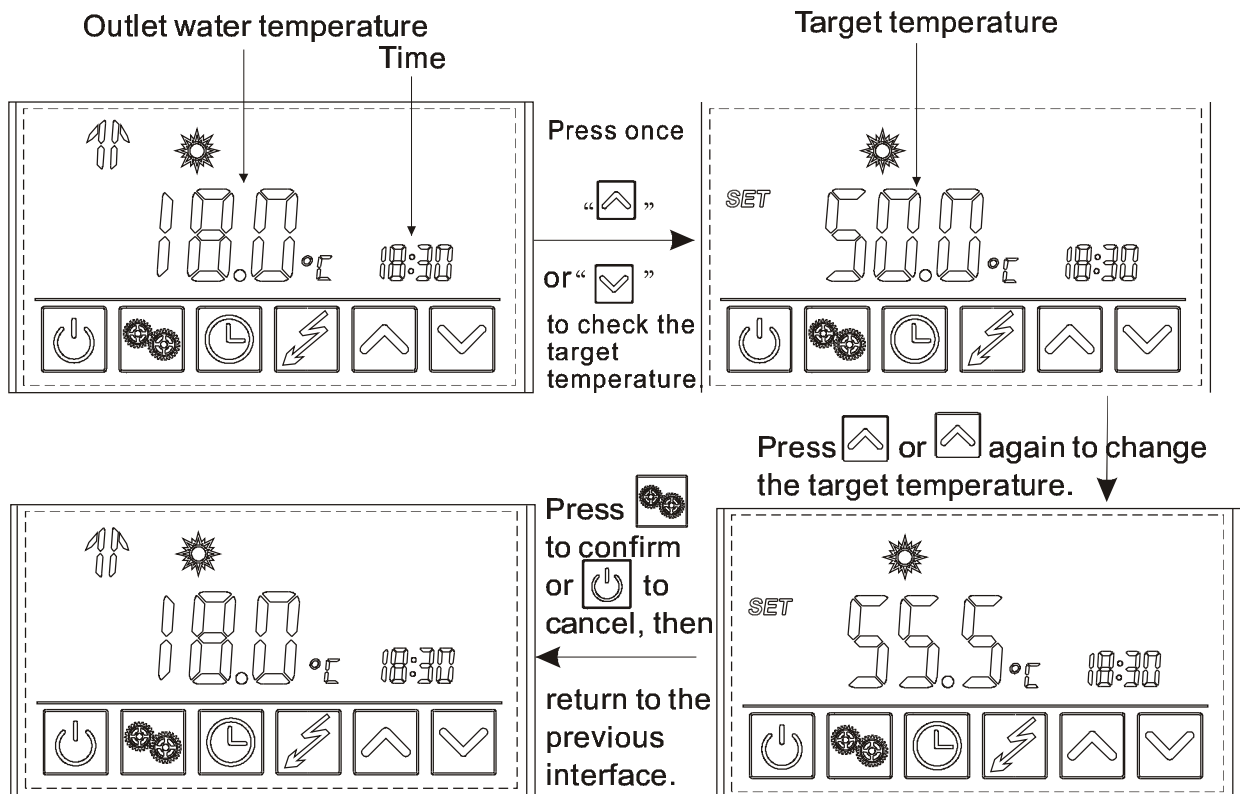

2.4 Timesetting

In the standby or running interface, do as follows to set the time when in heating mode. When press "⌚" once, the time parameter will flash. When press "⌚" again, the hour parameter will flash then press "↑" or "↓" to change it. After making the changes to the parameter, press "⏻" to confirm, then change the minute parameter as well as the date parameter in the same way.

If no operations are performed on the keypad for 10s, the controller exits the parameter modification menu by timeout and the changes are confirmed.

Note: Set the date in the same way when in vacation mode.

Example: Change the time and date from 18:30 on August 4th to 17:40 on September 8th.

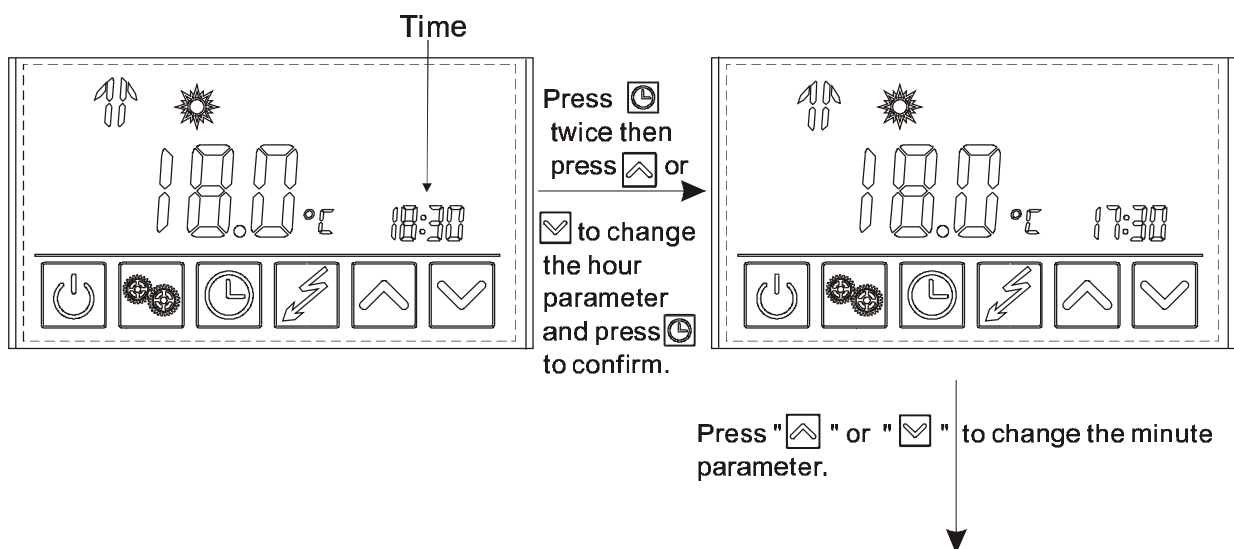

6. Usage

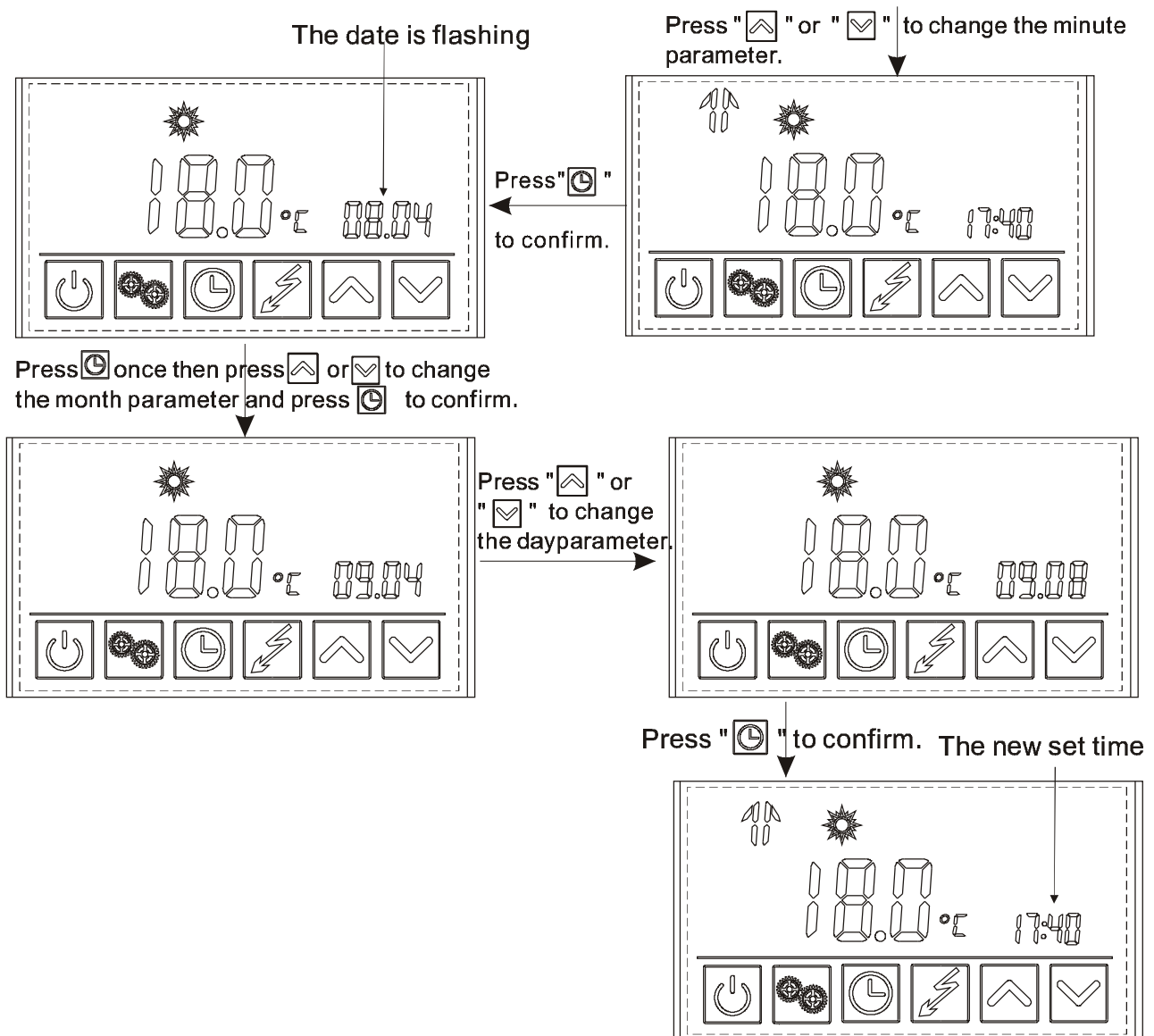

2.5 Timersetting

2.5.1 In the heating mode, two running periods can be set.

Press "⏸" and hold for 2s to enter into the timersetting interface.

Running period 1: The symbol "ON 1" on the right side of the interface and the time parameter flash at this time. Press "⏸" again and the hour parameter flashes. Set the time according to the "2.6" and confirm. Then "OFF 1" and the time parameter flash. Set the time following the previous steps.

Running period 2: After Running period 1 is set, the controller will enter into the Running period 2 setting interface. Set the start-up and shut-down time in the same way as Running period 1.

Press "⏸" to cancel any modifications during the setting.

Press "⏸" and hold for 2s twice to set the "OFF 1" time directly or press "⏵" "⏶" when the unit is already running.

Press "⏸" cancel the setting when the hour parameter is flashing.

6. Usage

Heating mode

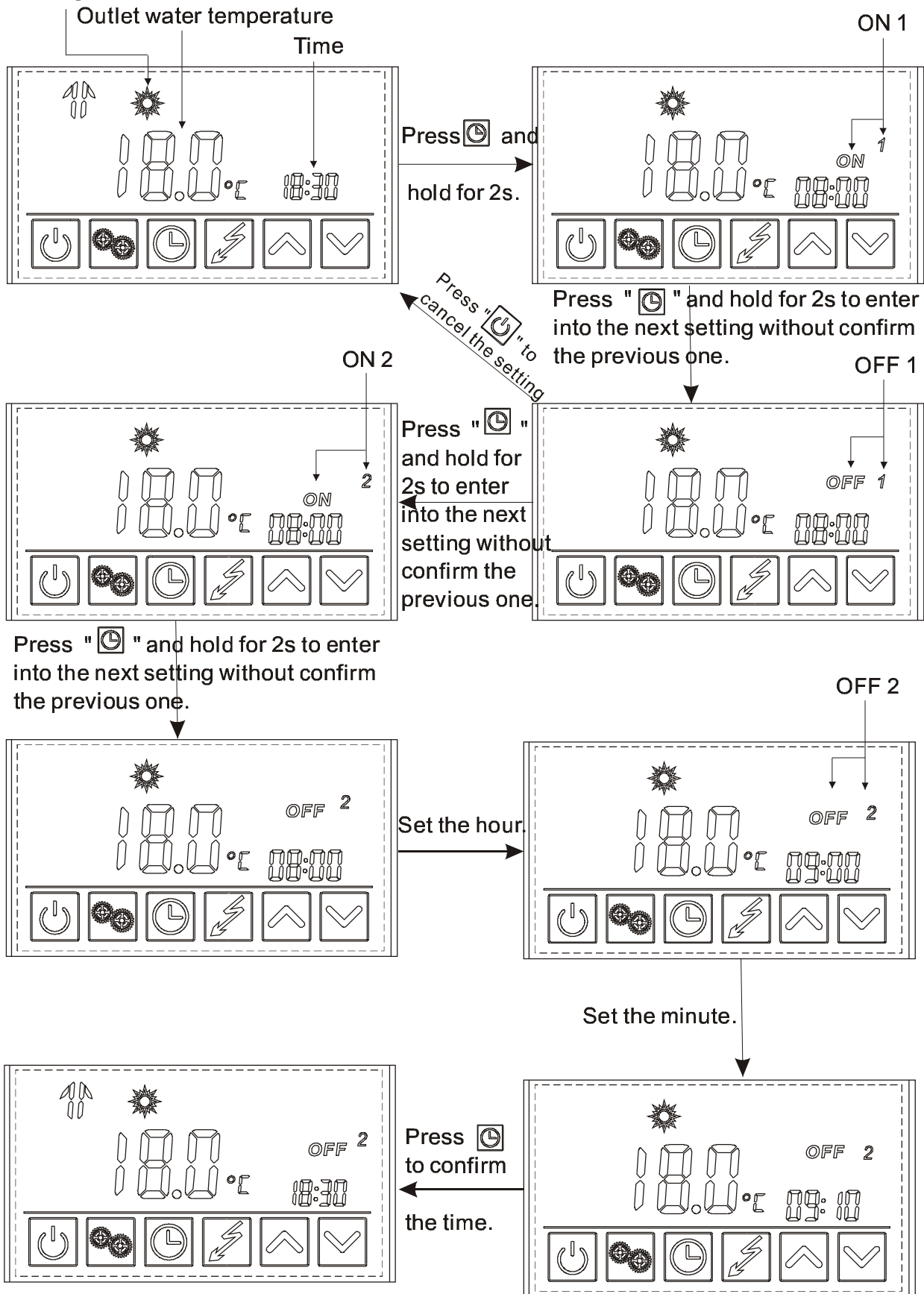

6. Usage

Example: **Running period 1:** 8:00~10:00; **Running period 2:** 16:30~22:00.

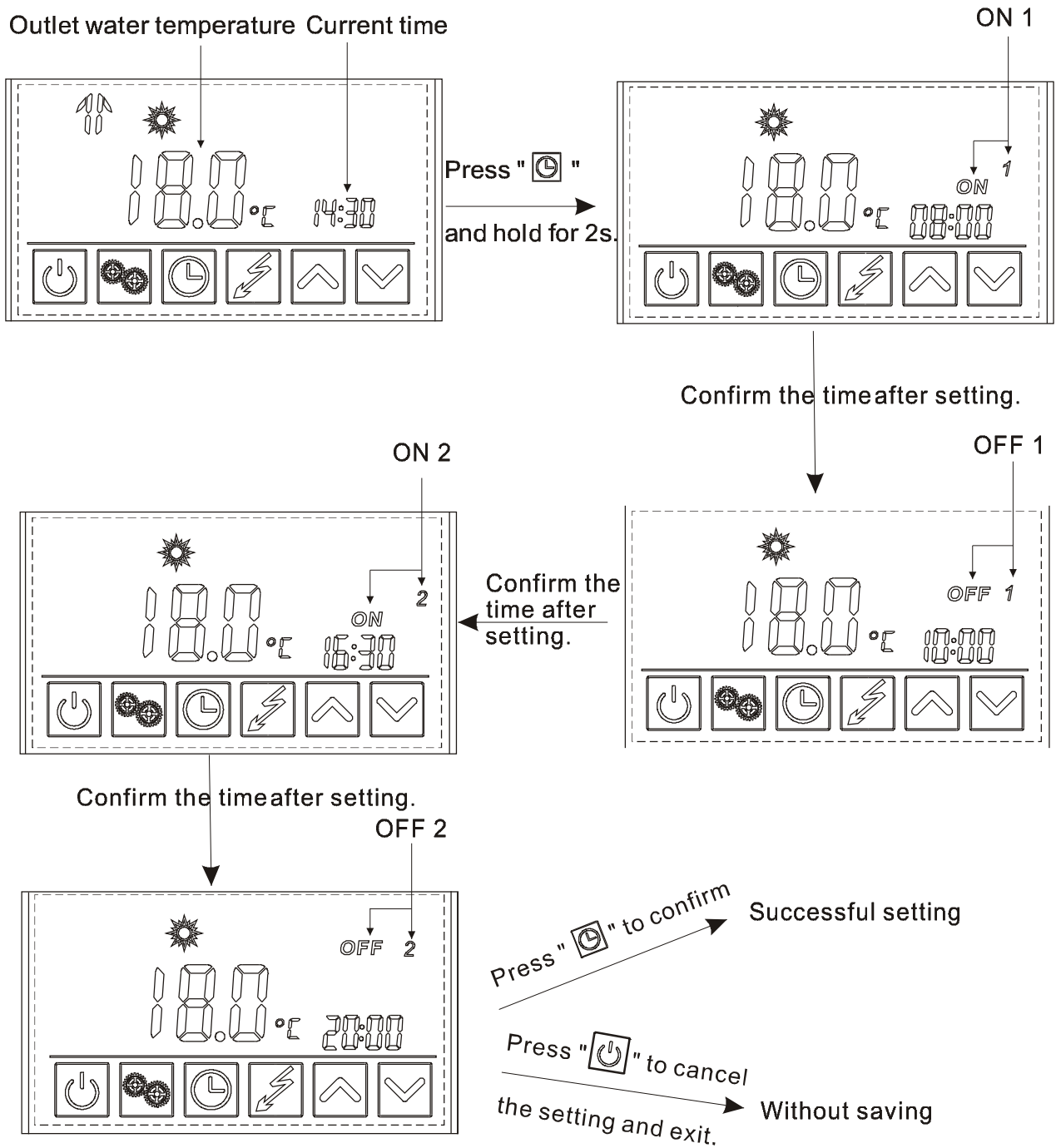

6. Usage

If you want to cancel the timer setting ,follow this below

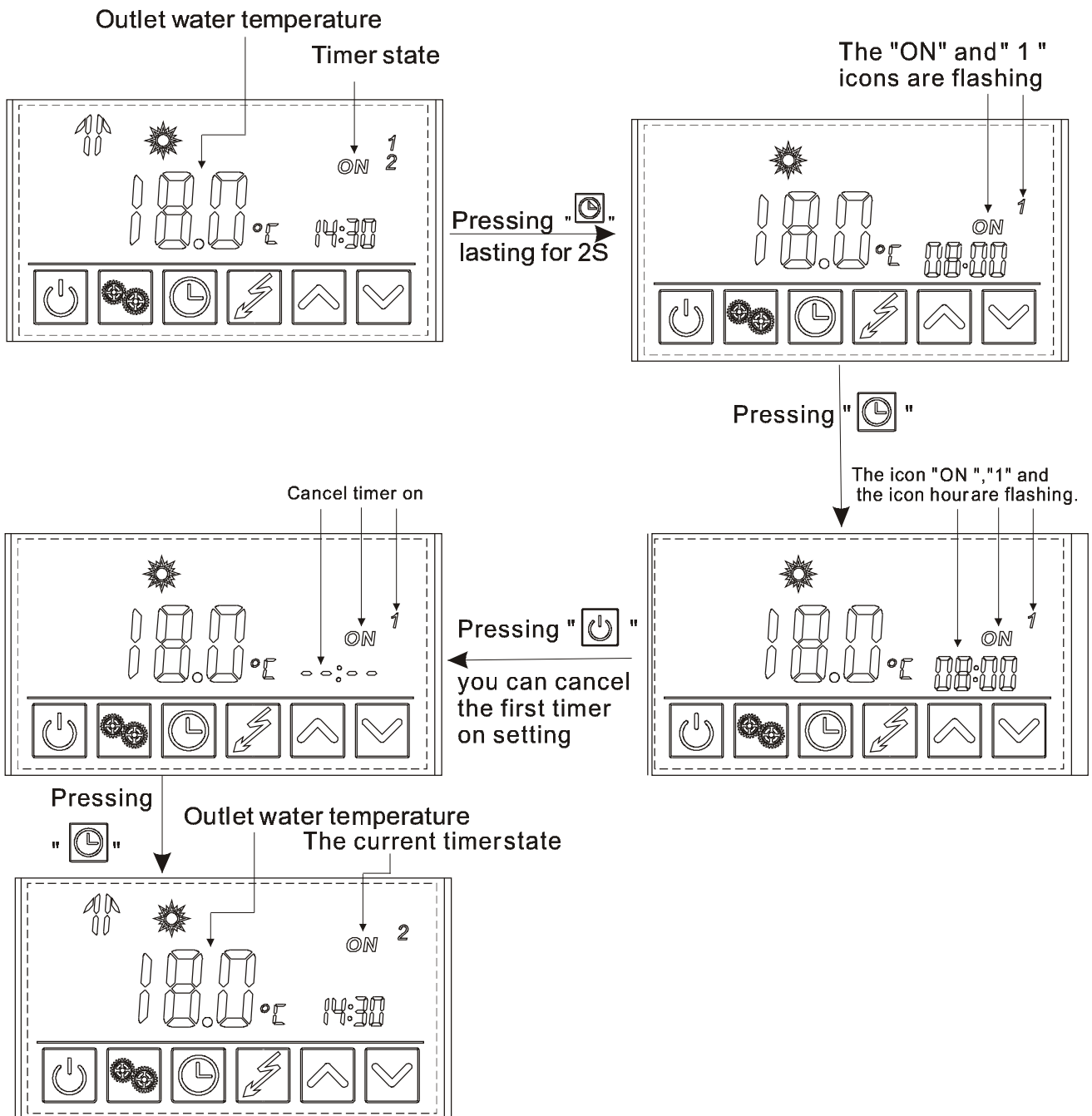

2.5.2 In the invocation mode

Press " [Timer Icon] " and hold for 2s to enter into the timer setting interface. The symbol "ON" and the date parameter are flashing at this time. Then set the date in the same way as "2.6".

6. Usage

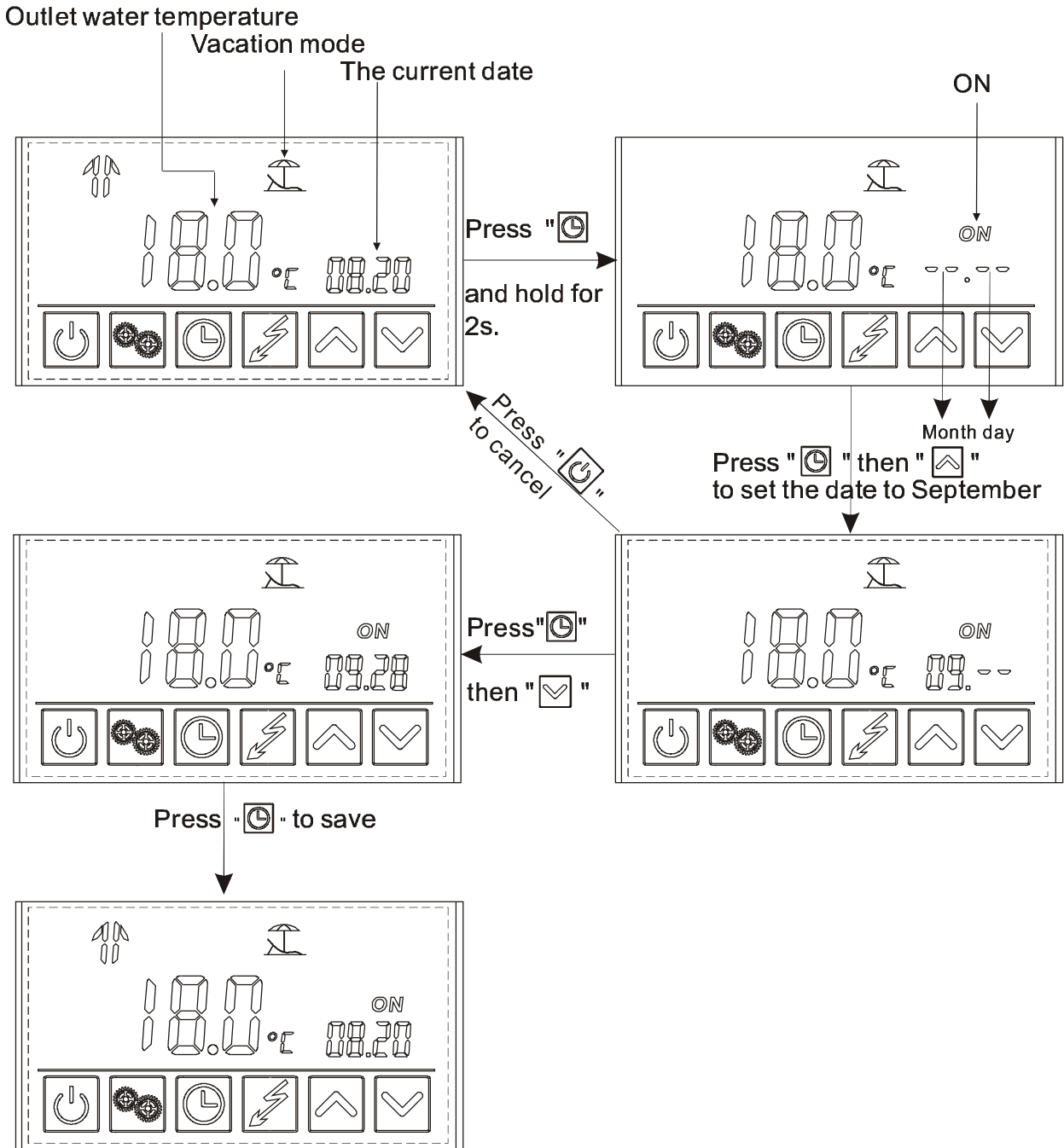

6. Usage

2.6 Electric heater setting

The electric heater can be turned on when the unit is heating or standby.

Press "⚡" once to turn on the electric heater and press "⚡" again to shut it off.

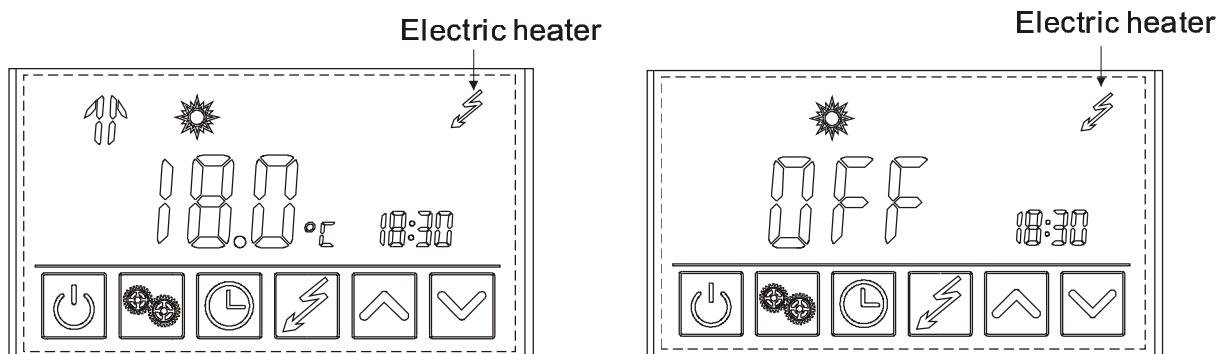



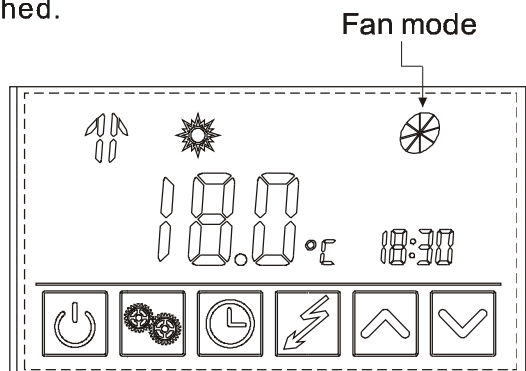

2.7 Fan mode setting

Press "⚡" and hold for 2s for the first time to change the fan mode to low speed running and the fan will run at low speed when the unit target temperature is reached. Press "⚡" and hold for 2s again to change the fan mode to high speed running and the fan will run at high speed when the unit target temperature is reached. Press "⚡" and hold for 2s for the third time to change the fan mode to shut-down and the fan will stop running when the unit target temperature is reached.



Definition of the fan icon

1.  (Running) : shows that the fan is running at high speed
2.  (Running): shows that the fan is running at low speed.
3. Fan icon disappears: shows that the fan is shut off.
4.  (Static) : shows that the fan will run at high speed when target setting temperature is reached.
5.  (Static) : shows that the fan will run at low speed when target setting temperature is reached.

6.Usage

2.8 Keyboard locking

Press "☰" and hold for 5s once to lock the keyboard. Press "☰" and hold for 5s again to unlock the keyboard.

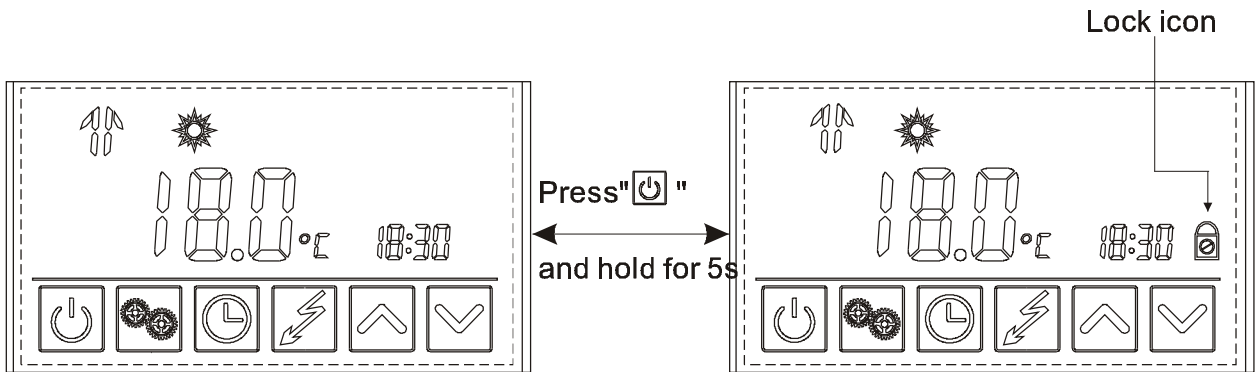

3.Parameter list

Definition	Default	Note
Target temperature	55°C	Adjust

7. Maintenance and repair

7.1 Maintenance

- Check the water supply and air vent frequently, to avoid lack of water or air in the water loop. Clean the water filter in a certain period to keep good water quality. Lack of water and dirty water can damage the unit. The heat pump will start the water pump per 72 hours when it is not running, to avoid freezing.
- Keep the unit in a place which is dry and clean, and has good ventilation. Clean the heat exchanger in 1 or 2 months and keep good heat exchange rate and save energy.
- Check each part of the unit and the pressure of the system. Replace the failure part if there is any, and recharge the refrigerant if it is needed.
- Check the power supply and the electrical system, make sure the electrical components are good, the wiring is well. If there is any part failed with wrong action or smell, please replace in time.
- If the heat pump is not used for a long time, please drain out all the water in the unit and seal the unit to keep it good. Please drain the water from the lowest point of the heat exchanger to avoid freezing in winter. Water recharge and full inspection on the heat pump is needed before it is restarted.
- Don't power off the unit when you use it in continuity, or the water in the pipe will freeze and split the pipe. We will not answer for this damage.

7.2 The normal failure and solutions

For any malfunctions, please refer to the table below:

Malfunction	Display	Cause	Solution
Bottom water temp. Failure	P01	The water bottom temp. Sensor is open or short circuit	Check or change the water bottom temp. Sensor
Top tank water temp. Failure	P02	The water top tank temp. sensor is open or short circuit	Check or change the water top tank temp. Sensor
Ambient temp. Failure	P04	The ambient temp. sensor is open or short circuit	Check or change the ambient temp. Sensor
Coil temp. Failure	P05	The pipe temp. sensor is open or short circuit	Check or change the pipe temp. Sensor
Refrigerant absorb temp. Failure	P07	The evaporator temp. Sensor is open or short circuit	Check or change the evaporator temp. Sensor
Anti-freeze temp. Failure	P09	The anti-freeze temp. Sensor is open or short circuit	Check or change the anti-freeze temp. Sensor
High pressure protection	E01	The exhaust pressure is high , high pressure switch action	Check high pressure switch and cooling return circuit
Low pressure protection	E02	The suction pressure is low, Low pressure switch action	Check low pressure switch and cooling return circuit
Water flow failure	E03	No water or litter water in water system	Check the flow volume , water pump is failure or not
Electric-heater overheat protection	E04	Water flow volume not enough, Water system pressure difference is small	Check the flow volume, water system is jammed or not
Anti-freeze protection	E07	Water flow volume not enough, Water system pressure difference is small	Check the flow volume, water system is jammed or not
Anti-freeze protect level 1	E19	Ambient temperature is too low	
Anti-freeze protect level 2	E29	Ambient temperature is too low	

8. Appendix

1. PCB I/O port

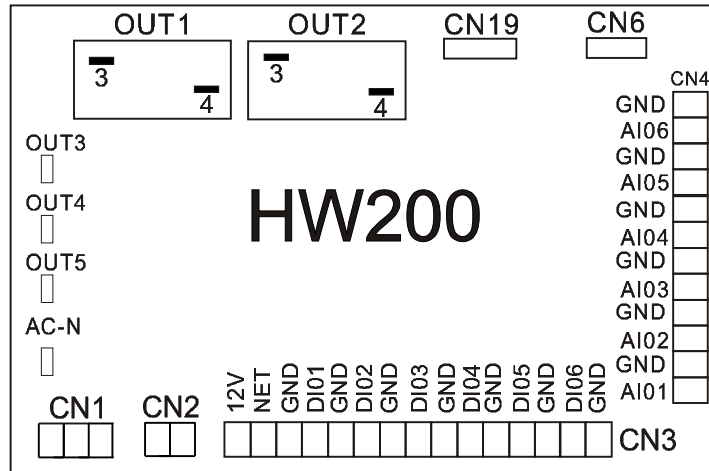

NO.	Symbol	The definition of the ports
1	OUT1	Compressor(output)(220-230VAC)
2	OUT2	Heater (output) (220-230VAC)
3	OUT3	Four way valve(output)(220-230VAC)
4	OUT4	High speed fan/Sourcepump (output) (220-230VAC)
5	OUT5	Low speed fan/Circulate pump/Solar pump/ Recovery pump/Cooling(output)(220-230VAC)
6	AC-N	Ground
7	NET GND 12V	Remote controller
8	DI01 GND	Remote ON/OFF
9	DI02 GND	Over heat protection
10	DI03 GND	Low pressure protection
11	DI04 GND	High pressure protection
12	DI05 GND	(SPARE)
13	DI06 DND	Flow swtich protection
14	AI01 GND	Ambient temp. sensor(input)
15	AI02 GND	Tank of bottom temp. Sensor(input)
16	AI03 GND	Tank of top temp. Sensor(input)
17	AI04 GND	Coil temp. Sensor/Anti-freeze Sensor(input)
18	AI05 GND	Suction temp. sensor(input)
19	AI06 GND	Solar temp. sensor(input)
20	CN6	Running indication/Circulate pump/Solar pump

9. Caution & Warning

Caution & Warning

1. The unit can only be repaired by qualified installer centre personnel or an authorised dealer. (for Europe market)
2. This appliance is not intended for use by persons (including children) with reduced physical sensory or mental capabilities, or lack of experience and knowledge, unless they have been given supervision or instruction concerning use of the appliance by a person responsible for their safety. (for Europe market)
Children should be supervised to ensure that they do not play with the appliance.
3. Please make sure that the unit and power connection have good earthing, otherwise may cause electrical shock.
4. If the supply cord is damaged, it must be replaced by the manufacturer or our service agent or similarly qualified person in order to avoid a hazard.
5. Directive 2002/96/EC (WEEE):
The symbol depicting a crossed-out waste bin that is underneath the appliance indicates that this product, at the end of its useful life, must be handled separately from domestic waste, must be taken to a recycling centre for electric and electronic devices or handed back to the dealer when purchasing an equivalent appliance.
6. Directive 2002/95/EC (RoHS): This product is compliant with directive 2002/95/EC (RoHS) concerning restrictions for the use of harmful substances in electric and electronic devices.
7. The unit CANNOT be installed near the flammable gas. Once there is any leakage of the gas, fire can occur.
8. Make sure that there is a circuit breaker for the unit, lack of circuit breaker can lead to electrical shock or fire.
9. The heat pump located inside the unit is equipped with an over-load protection system. It does not allow for the unit to start for at least 3 minutes from a previous stoppage.
10. The unit can only be repaired by the qualified personnel of an installer center or an authorized dealer. (for North America market)
11. Installation must be performed in accordance with the NEC/CEC by authorized person only. (for North America market)
12. USE SUPPLY WIRES SUITABLE FOR 75°C.
13. Caution: Single wall heat exchanger, not suitable for potable water connection.
14. The water may drip from the discharge pipe of the pressure-relief device and that this pipe must be left open to the atmosphere.

www.adtherm.gr

www.adgreen.gr



Code:20130306-0001